



**Ford Motor Company: Hybrid Driveline
Design & Control**

1. Context

One of the most popular hybrid vehicles on the road today is the Ford Fusion Hybrid. Winner of the Car of the Year award at the 2010 North American International Auto Show in Detroit, the Ford Fusion Hybrid has become both a technological and commercial success for Ford Motor Company.

Ford Motor Company (www.Ford.com) dedicates considerable resources to improving the design of products like the Fusion Hybrid by using Hardware-in-the-Loop (HIL) testing technologies. These HIL technologies can be applied to all aspects of vehicle design including engine control development, transmission control, body electronics, chassis control systems and traffic control & active safety systems.

In many cases, the HIL simulation approach is a valuable alternative to testing with physical prototypes since testing with physical prototypes early in the design process can result in costly damage to physical hardware.

Hybrid driveline design and control is one of the key aspects of the next generation of hybrid vehicle, including the Ford Fusion Hybrid. At the heart of the hybrid driveline is the electric motor drive. Although electric motor drive technology is very mature, its use in the automotive industry is new. In addition, simulation of these electric motor drives poses a number of challenges for Ford engineers. As a result, caution must be taken to ensure that the safety and reliability of hybrid driveline designs meets the very high quality expectation of Ford's customers.

2. Challenge

Modern automotive design architectures rely heavily on new, complex power electronic, electrical and mechanical systems, which often must be designed, tested and integrated concurrently. Although these new technologies represent the future of the auto industry, they must also be engineered within ever-shrinking development times, within budget and with a high degree of quality and reliability.



In the case of the Ford Fusion Hybrid, as with most hybrid vehicle designs, Permanent Magnet Synchronous Motors (PMSM) are used because of their high efficiency and high power density. A PMSM drive is typically composed of a PMSM and a 3-phase IGBT inverter. In hybrid car applications, the inverter is typically driven by an HIL-connected controller with PWM frequencies in the 2-20 kHz range, and dead-time in the range of 2-20 μ s. These specifications presented Ford with important simulation challenges requiring development of an effective control strategy that takes advantage of some key elements.

Simulation of this kind of PMSM drive is problematic for several reasons. Most notably that the PWM signal driving it typically has a high frequency. Also, some consecutive switching events, like dead-time, are shorter in interval than the achievable time-step of the simulator. Electric motor drives also have bandwidth that is sometimes several orders of

magnitude higher than their Instrument Control Electronics (ICE) counterparts and therefore require much smaller simulation stepsizes.

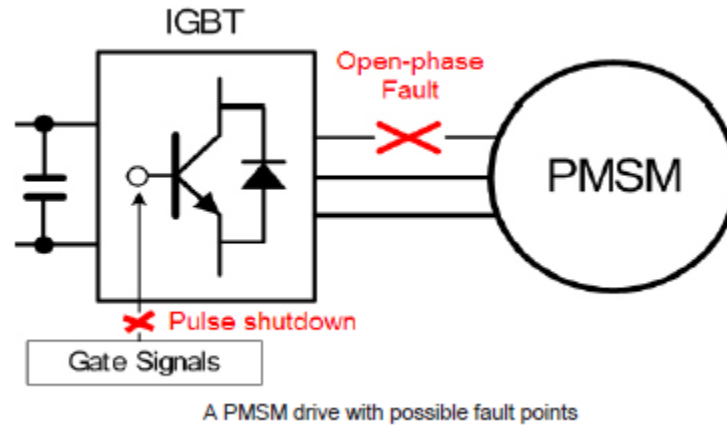

3. Solution

The textbook approach to simulating a drive with events in the μs range is to use a very small sample time (sub- μs range), but this is not realistic using a CPU-based simulation approach.

Alternatively, the 'Time-Step Averaging Method' (TSAM) can be used, where the inverter conduction time is computed directly from high-definition sampling of the gate signals at the I/Os.

To meet these simulation challenges and implement an effective control strategy, Opal-RT supplied Ford Motor Company with an eDRIVESim Real-Time HIL Simulator.

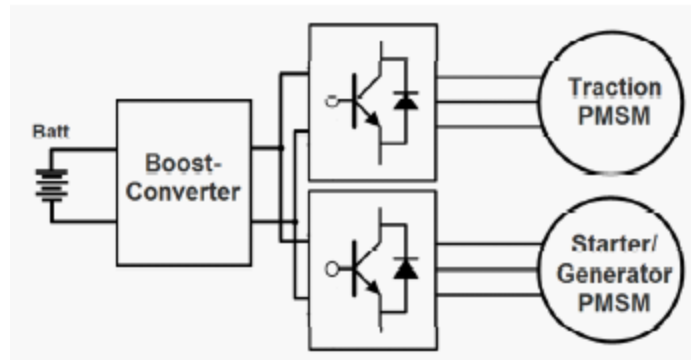

Dual-PMSM hybrid motor drive configuration

The eDRIVESim HIL Simulator is equipped with Opal-RT's RT-LAB Real-Time Simulation software platform. Simulator hardware is comprised of multi-core processors (dual quad-core Intel i7 processors) and FPGA-based I/O. High-density re-programmable FPGA-based I/Os are used to provide for up to 256 channels of time-stamped digital I/O with a resolution as low as 10 nanoseconds or 128 fast 16-bit analog converters with 1 μ s conversion times. The FPGA card also allows embedded simulation of PMSM motor drives.

The real-time kernel of the RT-LAB simulator used at Ford is QNX. Red Hat Linux is also supported as a real-time OS (RTOS). These optimized RTOS now enable simulation sample times as low as 7 μ s with I/Os. The simulator comes with the RTeDRIVE Simulink library to provide real-time compatible inverter and PMSM models. Real-Time Workshop from MathWorks is used to generate real-time code used by the simulator. Alternatively, Xilinx System Generator can also be used to generate high-level models targeted at the eDRIVESim FPGA boards (Spartan-3 or Virtex-5).

OPAL-RT also developed special inverter models for Ford using the TSAM approach that support 'high-impedance' mode in which the inverter current is zero, which is particularly important when simulating in faulty or rectifying modes.

The production controller was attached to the real-time simulator and tested accordingly, as if it were attached to the real driveline. To obtain the maximum simulation speed, the model is distributed across the 4 CPU cores available on the eDRIVEsim target, as depicted below.

Each motor drive is allocated a CPU core; the boost converter circuit and all the power electronics I/Os are allocated a 3rd core. The 4th core is used for general purpose I/Os and sensor I/Os.

Several tests were conducted at Ford Motor Company to verify the effectiveness of the control strategy, as well as basic protection schemes.

These included:

Test 1: Phase over-current detection.

This test aims to verify that the motor will shut down if a current limit is exceeded.

Test 2: Boost converter action caused by speed increase.

For this test, the motor initially turns at 1000 RPM with no torque applied. Then the speed is increased to 7000 RPM.

Test 3: VVC boost by changing torque command.

In this test, the motor initially runs at 1000 RPM and null torque command. Then, the torque command is modified to 75 N.m.

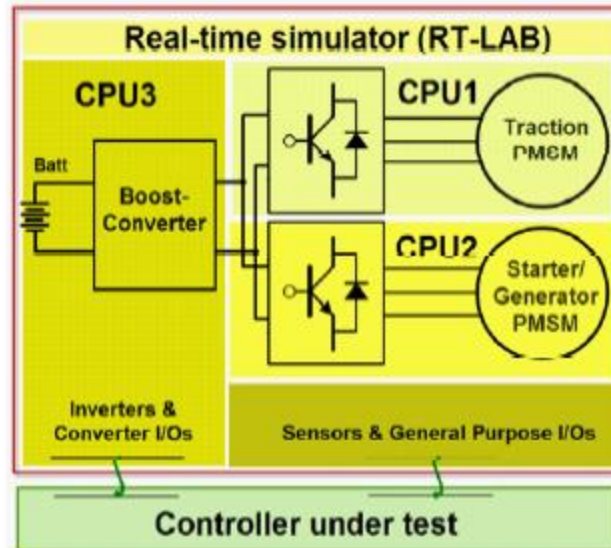

4. Conclusion

The use of HIL simulation to simulate test conditions and vehicle behavior, and hybrid vehicle components such as motor drive and driveline, has resulted in reduced development times and costs, and higher quality products.

HIL-based testing using an eDRIVEsim real-time simulator offers an efficient way to conduct these tests. Because of the high bandwidth of electric motor drives, it is necessary to simulate them with very small sample times. In addition, special inverter models were designed using the TSAM approach. These models are based on the switching function approach, but also support other modes like open-phase faults and natural rectification modes.

Used in a high-performance real-time platform, these models enable Ford Motor Company to successfully conduct numerous HIL tests on the Ford Fusion Hybrid motor drive controller.

For more information on how OPAL-RT helps Ford Motor Company build better cars, [click here](#) to read the technical paper authored by OPAL-RT and Ford and presented at the 2010 VPPC Conference.